



US007799442B2

(12) **United States Patent**
Iwawaki et al.

(10) **Patent No.:** **US 7,799,442 B2**
(45) **Date of Patent:** **Sep. 21, 2010**

(54) **FULL-COLOR ORGANIC EL PANEL**

(75) Inventors: **Hironobu Iwawaki**, Yokohama (JP);
Shinjiro Okada, Kamakura (JP); **Takao Takiguchi**, Tokyo (JP); **Satoshi Igawa**, Fujisawa (JP)

(73) Assignee: **Canon Kabushiki Kaisha**, Tokyo (JP)

(*) Notice: Subject to any disclaimer, the term of this patent is extended or adjusted under 35 U.S.C. 154(b) by 790 days.

(21) Appl. No.: **11/689,612**

(22) Filed: **Mar. 22, 2007**

(65) **Prior Publication Data**

US 2007/0228399 A1 Oct. 4, 2007

(30) **Foreign Application Priority Data**

Mar. 28, 2006 (JP) 2006-088353

(51) **Int. Cl.**
H01L 51/54 (2006.01)

(52) **U.S. Cl.** **428/690**; 428/917; 313/504;
313/506

(58) **Field of Classification Search** None
See application file for complete search history.

(56) **References Cited**

U.S. PATENT DOCUMENTS

5,714,968 A 2/1998 Ikeda 345/77

5,940,053 A 8/1999 Ikeda 345/77
6,011,529 A 1/2000 Ikeda 345/77
6,864,628 B2 3/2005 Yamazaki et al. 313/504
7,189,466 B2 3/2007 Moriyama et al. 428/690
7,400,088 B2* 7/2008 Ryu 313/504
2003/0044639 A1* 3/2003 Fukuda 428/690
2003/0076032 A1* 4/2003 Suzuri et al. 313/504
2004/0245922 A1* 12/2004 Ohshita et al. 313/504
2004/0263067 A1* 12/2004 Saitoh et al. 313/504
2005/0057150 A1* 3/2005 Kim et al. 313/504
2005/0221124 A1* 10/2005 Hwang et al. 428/690
2005/0249972 A1* 11/2005 Hatwar et al. 428/690
2007/0085473 A1 4/2007 Moriyama et al. 313/504
2007/0148492 A1 6/2007 Tsuboyama et al. 428/690

FOREIGN PATENT DOCUMENTS

JP 8054836 2/1996

* cited by examiner

Primary Examiner—Dawn Garrett

(74) *Attorney, Agent, or Firm*—Fitzpatrick, Cella, Harper & Scinto

(57) **ABSTRACT**

A full-color organic electroluminescent panel has red (R), green (G), and blue (B) color pixels that independently emit light. The organic electroluminescent panel includes a hole-injecting layer common to the red (R), green (G), and blue (B) color pixels and a plurality of hole-transporting layers. The hole-transporting layer in at least one of the red (R), green (G), or blue (B) color pixels differs from a corresponding hole-transporting layer in the remaining pixels.

5 Claims, 5 Drawing Sheets

PANEL

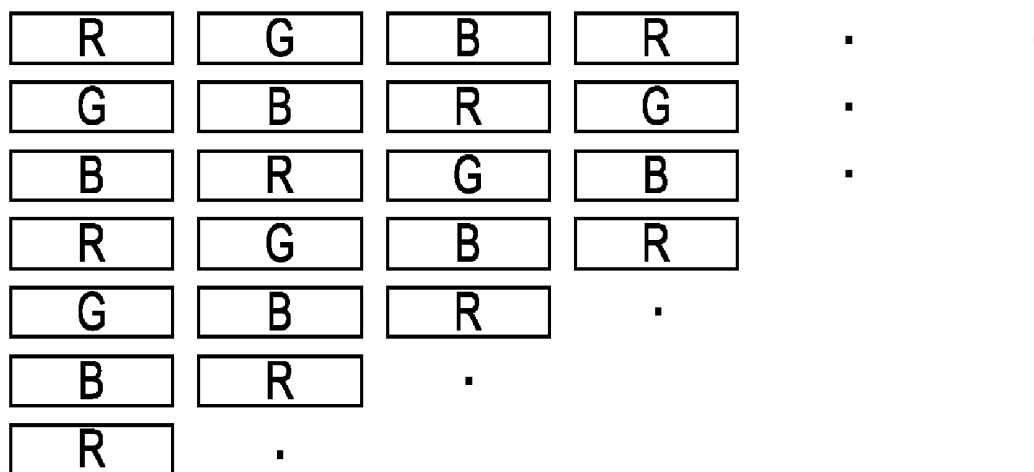

FIG. 1

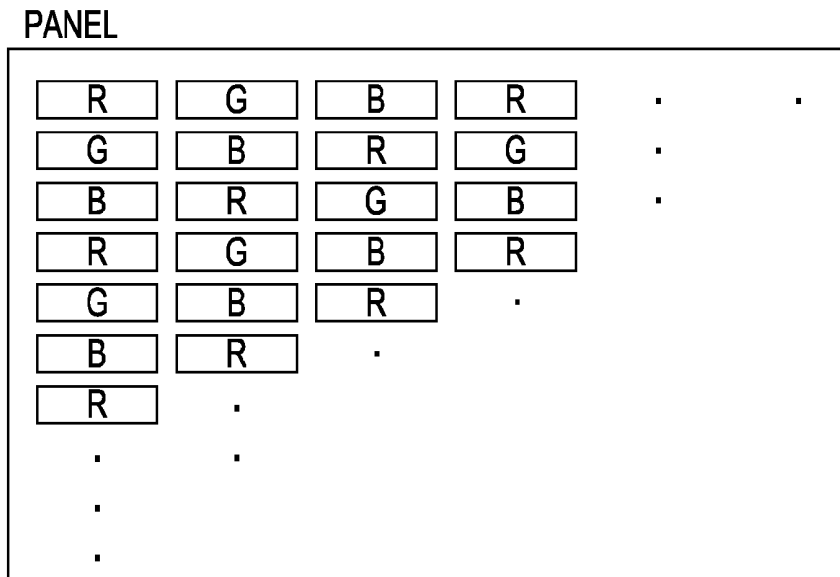

FIG. 2

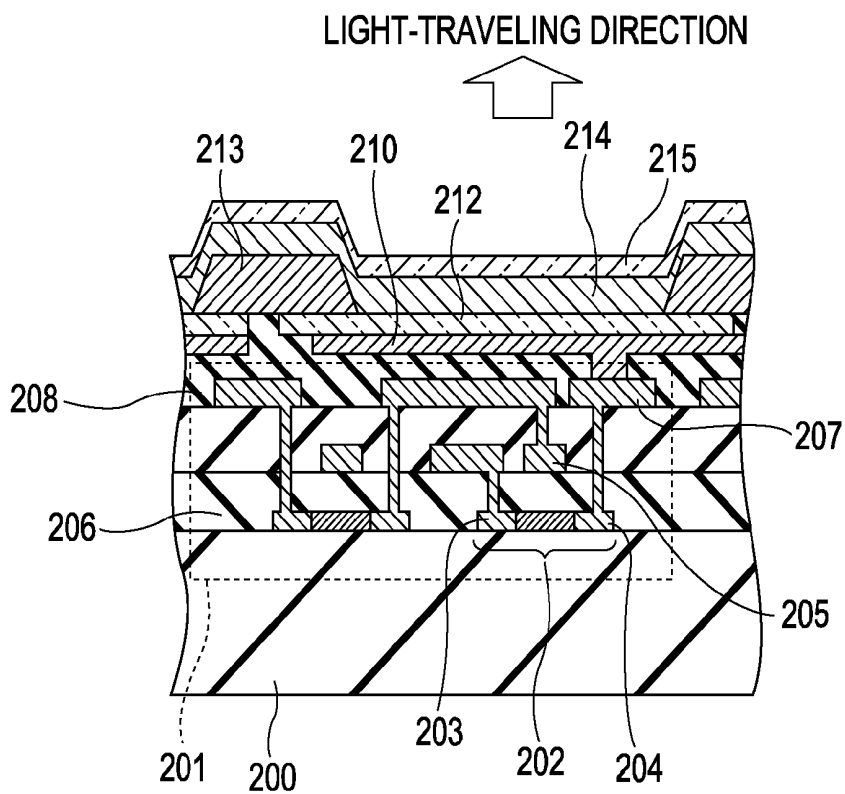

FIG. 3

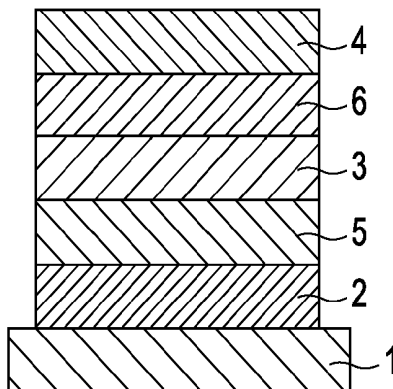

FIG. 4

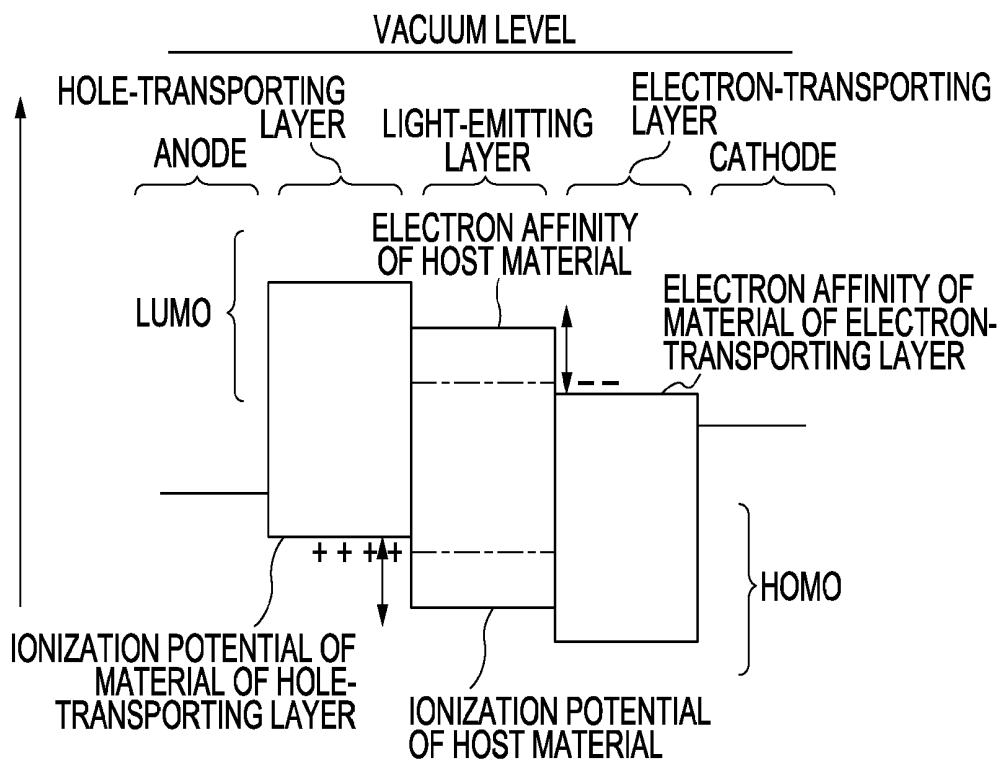

FIG. 5
PRIOR ART

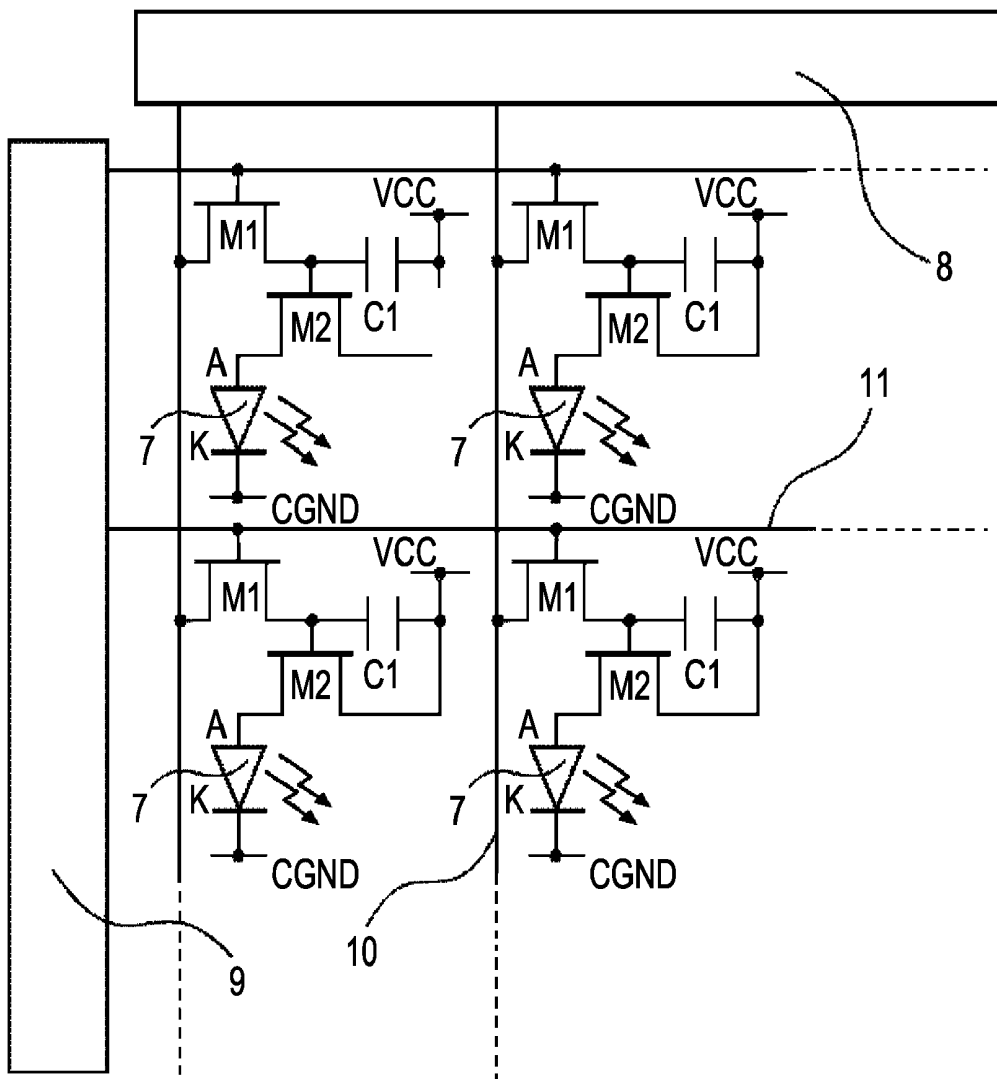

FIG. 6

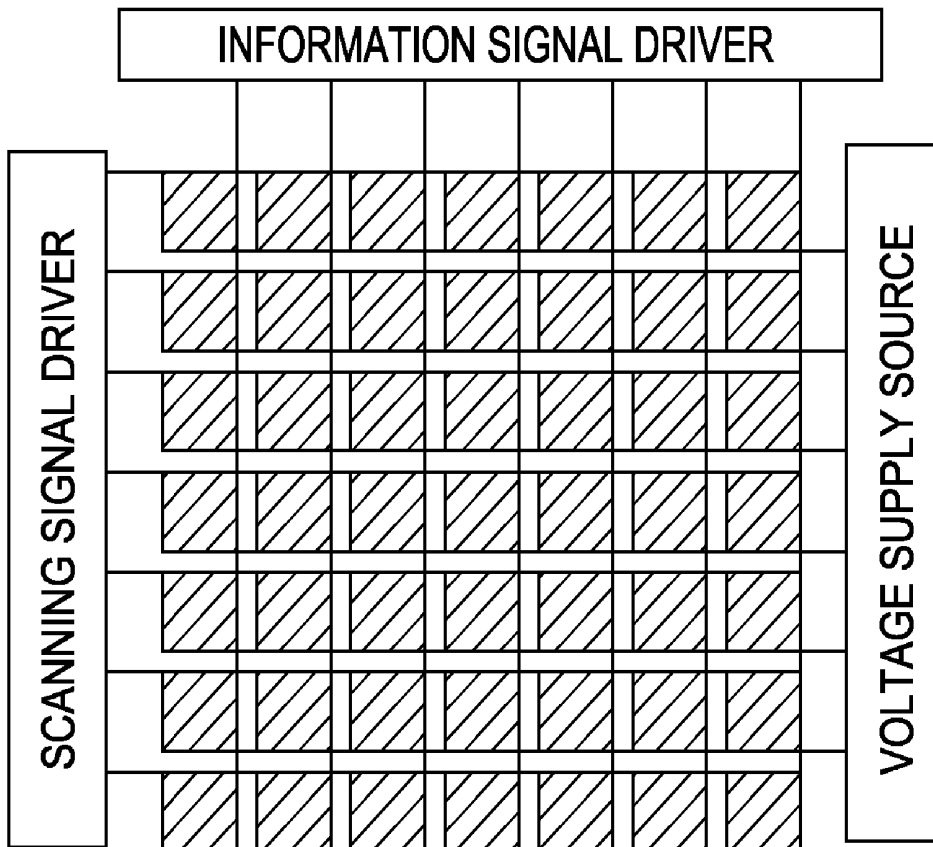
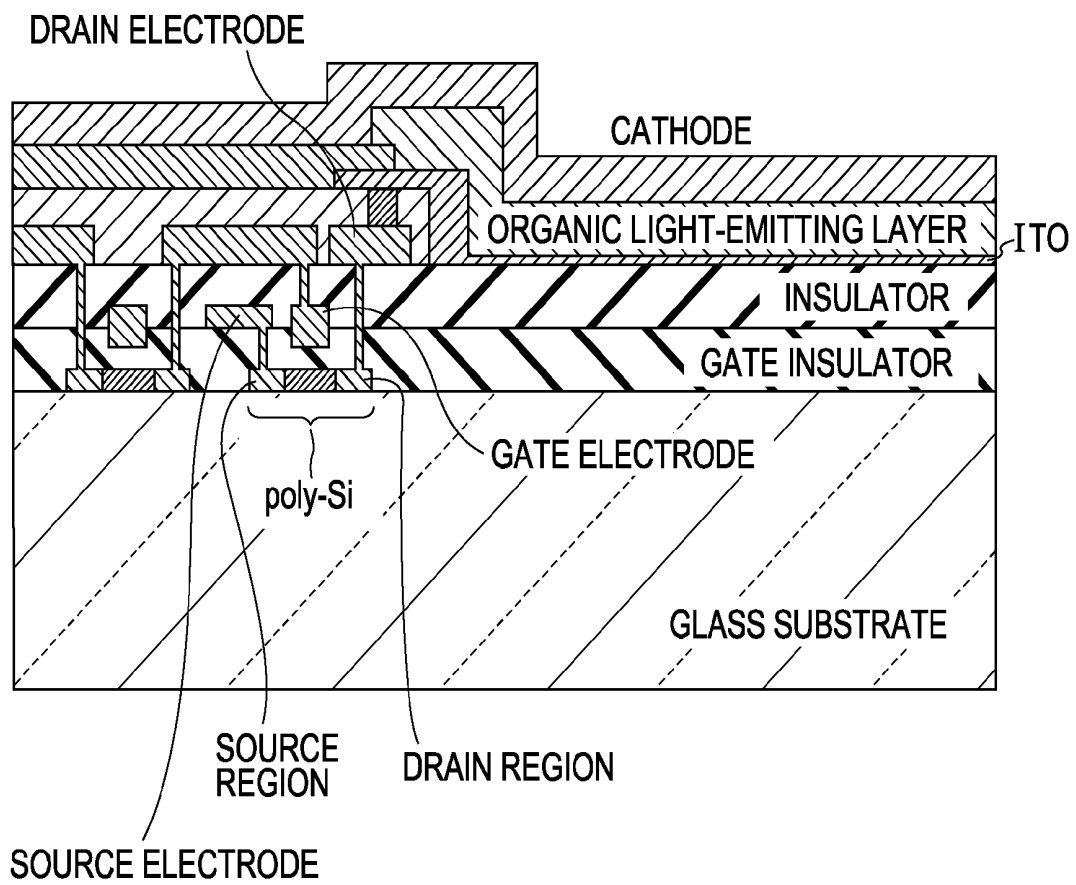

FIG. 7



FULL-COLOR ORGANIC EL PANEL

BACKGROUND OF THE INVENTION

1. Field of the Invention

The present invention relates to organic electroluminescent (EL) devices, and specifically to a full-color organic EL panel including at least red, green, and blue organic EL devices.

2. Description of the Related Art

Displays using organic EL devices have recently been intensively studied. Organic EL devices have advantages such as high luminance, wide viewing angles, and low power consumption, and have attracted attention as an alternative to liquid crystal displays for mobile applications.

Organic EL devices are separately driven for displaying. In general, organic EL devices emit light when supplied with current from a power supply disposed outside a display region where the devices are arranged. The current flows to a ground potential across electrodes of the organic EL devices, which are connected between the power supply potential and the ground potential, so that the devices can emit light.

Organic EL devices operate by passive-matrix driving, in which the intersections of orthogonal stripe electrodes are sequentially driven to emit light, or by active-matrix driving, in which thin-film transistors (TFTs) assigned to the individual devices control the driving thereof to emit light.

Japanese Patent Laid-Open No. 8-54836 discusses an example of an active-matrix light-emitting device. This light-emitting device includes an electron-injecting electrode connected to a drain electrode of a TFT via a contact hole, a hole-injecting electrode disposed opposite the electron-injecting electrode, and an organic thin-film layer disposed between the opposing electrodes. The hole-injecting electrode is formed of indium tin oxide (ITO), which is a typical transparent conductive material, so that light can be emitted through the hole-injecting electrode. The organic thin-film layer is supplied with a current controlled by the TFT to emit light.

FIG. 5 is a schematic diagram of an example of a conventional circuit for an active-matrix display. This circuit includes organic EL devices 7, a data-line drive circuit 8, a scanning-line drive circuit 9, data lines 10, scanning lines 11, switching TFTs M1 for controlling light emission of the devices 7, drive TFTs M2 for controlling the light output power of the devices 7, and hold capacitors C1 for maintaining the light emission.

The organic EL devices 7, the switching TFTs M1, the drive TFTs M2, and the hold capacitors C1 constitute individual pixel circuits which are arranged in a matrix. The organic EL devices 7 each have an anode A connected to a power supply potential VCC via the drive TFT M2 and a cathode K connected to a ground potential CGND.

Full-color images can be outputted by placing a color filter of the three primary colors of light, namely, red (R), green (G), and blue (B), on organic EL devices that emit white light, or by arranging organic EL devices that emit red, green, or blue light alternately in a dot matrix. The use of color organic EL devices is more advantageous in providing a display with higher luminance because they require no color filter and thus cause no loss of light. The optimum thickness and material of the color organic EL devices are different for each of the three primary colors. According to U.S. Pat. No. 6,864,628, red, green, or blue light-emitting devices include a plurality of hole-transporting layers to provide the optimum configuration for each color.

Battery life time is important for organic EL displays for mobile applications. Therefore, increased luminous effi-

ciency and decreased drive voltage are required of organic EL devices used for the displays to reduce power consumption. Also, an extended device life time is required for long-term use, and cost reduction is required for competition with liquid crystal displays.

SUMMARY OF THE INVENTION

As a result of intensive studies for solving the above problems, the inventors have completed the present invention.

The present invention provides a full-color organic electroluminescent panel having red (R), green (G), and blue (B) color pixels that independently emit light. The organic electroluminescent panel includes a hole-injecting layer common to the red (R), green (G), and blue (B) color pixels and a plurality of hole-transporting layers. The hole-transporting layer in at least one of the red (R), green (G), or blue (B) color pixels differs from a corresponding hole-transporting layer in the remaining pixels.

The full-color organic electroluminescent panel according to the invention can achieve low power consumption and excellent temporal stability in the light emission of all the color pixels, namely, the red, green, and blue pixels.

Further features of the present invention will become apparent from the following description of exemplary embodiments with reference to the attached drawings.

BRIEF DESCRIPTION OF THE DRAWINGS

FIG. 1 is a schematic diagram showing an example of an arrangement of red, green, and blue pixels of a full-color organic EL panel according to an embodiment of the present invention.

FIG. 2 is a sectional view of a pixel of the organic EL panel according to this embodiment.

FIG. 3 is a sectional view of an example of an organic EL device according to this embodiment.

FIG. 4 is an example of an energy band diagram of the organic EL device according to this embodiment.

FIG. 5 is a schematic diagram of an example of a circuit for a conventional active-matrix display.

FIG. 6 is a schematic diagram of an example of a TFT matrix organic EL panel in examples of the present invention.

FIG. 7 is a schematic sectional view of the organic EL panel in the examples of the present invention.

DESCRIPTION OF THE EMBODIMENTS

The present invention will now be described in detail.

FIG. 1 is a schematic diagram of a full-color organic EL panel according to an embodiment of the present invention. This panel has a light-emitting region where red, green, and blue pixels are regularly arranged in two dimensions.

The wavelength peaks of independent light emission of the red, green, and blue pixels in this embodiment are as follows:

Red (R): 600 to 640 nm

Green (G): 500 to 540 nm

Blue (B): 440 to 480 nm

Although the red, green, and blue pixels are regularly arranged in FIG. 1, they can be arranged in various arrangements. It is possible to arrange pixels of the same color in succession (for example, RRGGBB), to insert white (W) pixels (for example, RGBW), or to increase the number of pixels of a particular color (for example, RGGGB).

FIG. 2 is a sectional view of a pixel of the organic EL panel according to this embodiment. The pixel includes an anode and a cathode over a substrate 200 and an organic functional

layer **214** between the anode and the cathode. The functional layer **214** at least includes a hole-injecting/transporting layer, a light-emitting layer, and an electron-injecting/transporting layer that are stacked on top of each other. The light-emitting layer of each pixel emits red, green, or blue light.

Switching elements can be assigned to the individual pixels for light emission. These switching elements can separately control the light emission of the pixels. TFTs can be used as the switching elements. Pixels having TFTs can be arranged in two dimensions to display a two-dimensional image.

FIG. 2 shows a top-emission structure in which a reflective electrode layer **210** and a transparent electrode **212** constitute the anode and another transparent electrode **215** constitutes the cathode. The reflective electrode layer **210** and the transparent electrode **212** are disposed closer to a TFT **201** than the transparent electrode **215**. The organic EL panel can also employ a bottom-emission structure, which outputs light through a substrate having TFTs; however, the top-emission structure can be deemed preferable in terms of pixel aperture ratio because TFTs do not transmit light.

The organic EL panel according to this embodiment will be described in detail with reference to FIG. 2, although the present invention is not limited to this embodiment.

Each display pixel includes the TFT **201** and the organic EL device, which are formed on the substrate **200**. The substrate **200** is, for example, an insulating substrate such as a glass substrate or a synthetic resin substrate, or a conductive or semiconductor substrate having an insulating film such as a SiO₂ film or a SiN_x film. For top emission, the substrate **200** can be either transparent or nontransparent. The TFT **201** is formed on the substrate **200** to drive the organic EL device. The TFT **201** includes a polysilicon (poly-Si) active layer **202**. The material of the active layer **202** is not limited to polysilicon and can also be, for example, amorphous silicon or microcrystalline silicon. The TFT **201** is covered with an interlayer insulating film **208** having a contact hole. The reflective layer **210** is formed on the interlayer insulating film **208** and is electrically connected to a drain electrode **207** of the TFT **201**. In addition, the transparent electrode **212** (first electrode) can be formed on the reflective layer **210**. The transparent electrode **212** and the reflective layer **210** are formed by patterning for each pixel.

The reflective layer **210** can be formed of a highly reflective metal film such as a silver film, an additive-containing silver film, a silver alloy film, an aluminum film, an additive-containing aluminum film, an aluminum alloy film, or a chromium film.

The transparent electrode **212** is formed of, for example, a transparent conductive oxide film such as an ITO film or an indium zinc oxide (IZO) film.

In particular, the transparent electrode **212** can be connected to the reflective layer **210** or the drain electrode **207** under a pixel-separating film **213** that does not transmit light.

The pixel-separating film **213** is an insulating film disposed between the adjacent pixels so as to cover the periphery of the transparent electrode **212**. The pixel-separating film **213** is formed of, for example, silicon nitride, polyimide, or novolak resin.

The organic functional layer **214** is formed on the anode, namely, the transparent electrode **212**. The organic functional layer **214** includes a hole-transporting layer, a light-emitting

layer, a carrier-blocking layer, and an electron-injecting layer. The cathode, namely, the transparent electrode **215**, is formed on the organic functional layer **214**.

Light traveling toward the reflective layer **210** from a position where the light is emitted is reflected by an outer surface of the reflective layer **210** to return to the position where the light is emitted. The optical path length of the light is represented as $2(n_{org}d_{org}+n_{ito}d_{ito})$, where n_{org} and n_{ito} are the reflective indices of the organic functional layer **214** and the transparent electrode **212**, respectively, and d_{org} and d_{ito} are the thicknesses of the organic functional layer **214** and the transparent electrode **212**, respectively. If the optical path length is equal to, for example, $\lambda/2$, $3\lambda/2$, or $5\lambda/2$, interference between the reflected light and the emitted light is maximized.

The relationship described above is represented by the equation (2):

$$2(n_{org}d_{org}+n_{ito}d_{ito})=(2j+1)/2\lambda$$

$$\therefore(n_{org}d_{org}+n_{ito}d_{ito})=(2j+1)\lambda/4 \quad (2)$$

where j is an integer. That is, luminous efficiency is enhanced by interference if the optical path length between the position where the light is emitted and the reflective layer **210**, $(n_{org}d_{org}+n_{ito}d_{ito})$, is equal to an odd multiple of $\lambda/4$. Thus, the thickness of the organic functional layer **214** can be changed for each color because the optimum optical path length differs for each color. On the other hand, a common injecting layer can be used in terms of cost reduction and carrier injection from electrodes. Accordingly, a common injecting layer and transporting layers with different thicknesses can be used for the red, green, and blue pixels on the reflective electrode **210** side to achieve both cost reduction and increased efficiency.

The organic EL devices of the full-color organic EL panel according to this embodiment will be described in detail with reference to FIG. 3. FIG. 3 is a sectional view of an example of an organic EL device according to this embodiment.

In FIG. 3, the organic EL device includes an anode **2**, a hole-transporting layer **5**, a light-emitting layer **3**, an electron-transporting layer **6**, and a cathode **4** which are sequentially formed on a substrate **1**. In this structure, carrier transportation and light emission are functionally separated, and thus an appropriate combination of compounds having hole transport properties, electron transport properties, or light emission properties can be used. This increases the flexibility of material selection. In addition, this structure can increase the variety of hues of light because various compounds having different light emission wavelengths can be used. Furthermore, this structure can effectively trap carriers or excitons inside the central light-emitting layer **3** to enhance luminous efficiency.

Different hole-transporting layers and different electron-transporting layers can be used for red, green, and blue light-emitting layers according to the energy bands thereof. In particular, different materials can be used for the transporting layers of the red, green, and blue light-emitting layers to match the energy bands thereof, thereby providing the optimum configuration for each color. On the other hand, a common hole-injecting layer and a common electron-injecting layer can be used for the red, green, and blue light-emitting layers to facilitate uniform carrier injection from electrodes into the hole-injecting layer and the electron-injecting layer,

which are in contact with the electrodes. The electron injection/transport properties can be controlled by changing the concentrations of dopants for promoting injection (such as alkali metals and salts thereof) and the thicknesses of the layers.

On the other hand, a common hole-injecting layer can be used for the red, green, and blue light-emitting layers to ensure uniform hole injection properties, while different hole-transporting layers can be used for the red, green, and blue light-emitting layers to ensure the optimum hole transport properties for each color. Use of materials having similar molecular structures for the hole-injecting layer and the hole-transporting layers enhances the adhesion therebetween to facilitate injection.

Accordingly, the use of materials having a common component in their molecule structures for the hole-injecting layer and the hole-transporting layers provides higher stability than the use of materials having the same energy band but significantly different molecular structures. An example of such a common component is a fused ring structure, specifically, a carbocyclic aromatic group having 6 to 20 carbon atoms or a heterocyclic aromatic group having 5 to 20 carbon atoms. The use of such materials produces a significant effect on device life time in continuous driving.

The stacking effect of fluorenyl groups can be provided through the use of compounds having a component as represented by the general formula (1):

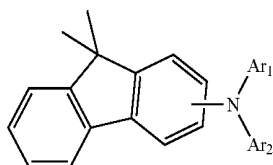

A fluorenyl group is more advantageous than other aryl groups in terms of hole mobility and heat resistance. Components having a developed π -conjugated system, such as pyrenyl and perylenyl groups, have an excessive stacking effect and thus require a bulky substituent such as an alkyl substituent, which decreases hole mobility. On the other hand, components having a relatively undeveloped π -conjugated system, such as a phenyl group, have an insufficient stacking effect in terms of crystallization and stability.

Examples of luminescent materials used for the light-emitting layers include fluorescent materials, which emit light from a singlet state, and phosphorescent materials, which emit light from a triplet state. Theoretically, the luminous efficiency of phosphorescent materials is triple that of fluorescent materials. In particular, the luminous efficiency of metal complexes having a heavy atom effect, typified by iridium complexes, is four times that of fluorescent materials. Thus, the use of a phosphorescent material for the light-emitting layers of at least one of the three colors contributes to a reduction in power consumption. In particular, the use of phosphorescent materials for the light-emitting layers of all colors contributes to a further reduction in power consumption.

The organic layers of the full-color organic EL panel according to this embodiment are generally formed by, for

example, vacuum deposition, ion deposition, sputtering, plasma processing, or a known coating method (such as spin coating, dipping, casting, a Langmuir-Blodgett (LB) technique, or inkjetting) with a suitable solvent. In coating, particularly, a thin film can be formed using a suitable binder resin. The full-color organic EL panel can have excellent heat resistance for, for example, in-vehicle applications, including cellular phones and car navigation systems.

The substrate used for the full-color organic EL panel according to this embodiment is not particularly limited and can be, for example, a nontransparent substrate such as a metal substrate or a ceramic substrate, or a transparent substrate such as a glass substrate, a quartz substrate, or a plastic sheet. In addition, a dielectric reflective film, for example, can be disposed on the substrate to control emitted light. Light can be output either by bottom emission (in which the light is outputted from the substrate side) or by top emission (in which the light is outputted from the side opposite the substrate).

The devices thus prepared may be covered with a protective layer or a sealing layer to prevent contact with, for example, oxygen and moisture.

The materials of the hole-injecting layer and the hole-transporting layers in this embodiment are exemplified by the general formula (1), where Ar₁ and Ar₂ are each a substituted or unsubstituted aryl group. Examples of aryl groups include carbocyclic aromatic groups such as phenyl, naphthyl, and fluorenyl groups and heterocyclic aromatic groups such as pyridyl, thienyl, quinolyl, carbazolyl, and diarylamino groups.

Ar₁ and Ar₂ can be a carbocyclic aromatic group having 6 to 20 carbon atoms or a heterocyclic aromatic group having 5 to 20 carbon atoms which is unsubstituted or has at least one substituent selected from, for example, halogen atoms, alkyl groups, alkoxy groups, and aryl groups. Particularly, Ar₁ and Ar₂ can be a carbocyclic aromatic group having 6 to 20 carbon atoms which is unsubstituted or has at least one substituent selected from halogen atoms, alkyl groups having 1 to 14 carbon atoms, alkoxy groups having 1 to 14 carbon atoms, and aryl groups having 6 to 10 carbon atoms, or can be an aryl-substituted amino group. More particularly, Ar₁ and Ar₂ can be a carbocyclic aromatic group having 6 to 16 carbon atoms which is unsubstituted or has at least one substituent selected from halogen atoms, alkyl groups having 1 to 4 carbon atoms, alkoxy groups having 1 to 4 carbon atoms, and aryl groups having 6 to 10 carbon atoms.

Examples of Ar₁ and Ar₂ include, but not limited to, phenyl, naphthyl, anthracenyl, fluorenyl, pyrenyl, phenanthrenyl, chrysenyl, fluoranthenyl, triphenylenyl, perylenyl, pyridyl, pyrazinyl, pyrimidinyl, pyridazinyl, quinolinyl, isoquinolinyl, phenanthridinyl, acridinyl, naphthyridinyl, quinoxalinyl, quinazoliny, cinnolinyl, phthalazinyl, phenanthrolinyl, phenazinyl, thiazolyl, thienyl, furanyl, pyrrolyl, imidazolyl, benzothienyl, benzofuranyl, indolyl, dibenzothienyl, dibenzofuranyl, and carbazolyl groups. Examples of Ar₁ and Ar₂ also include aryl groups formed by combining at least two aryl groups so that they form a bond at any position. Typical examples of such aryl groups are as follows:

Compound 1

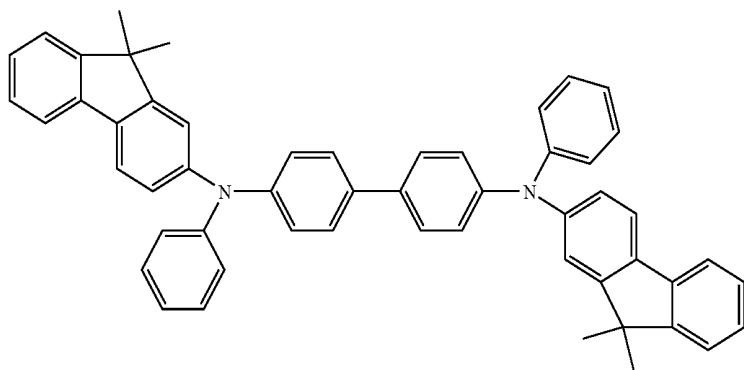

Compound 2

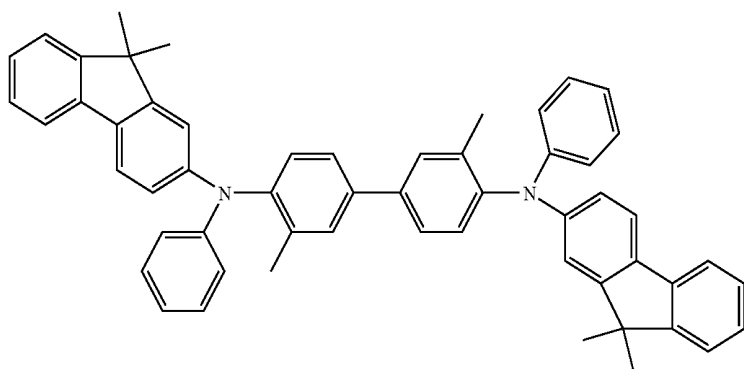

Compound 3

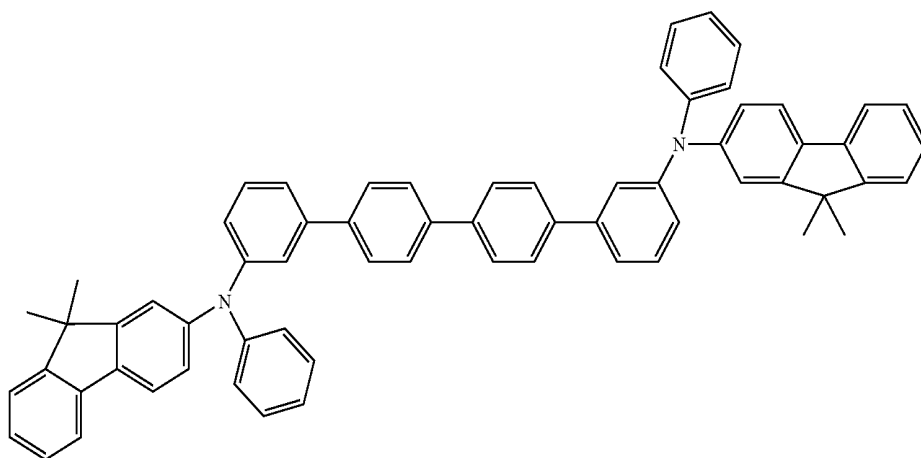

Compound 4

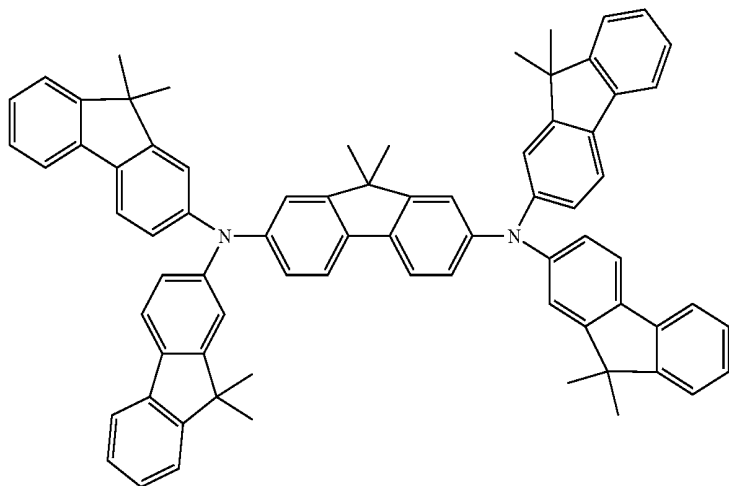

-continued

Compound 5

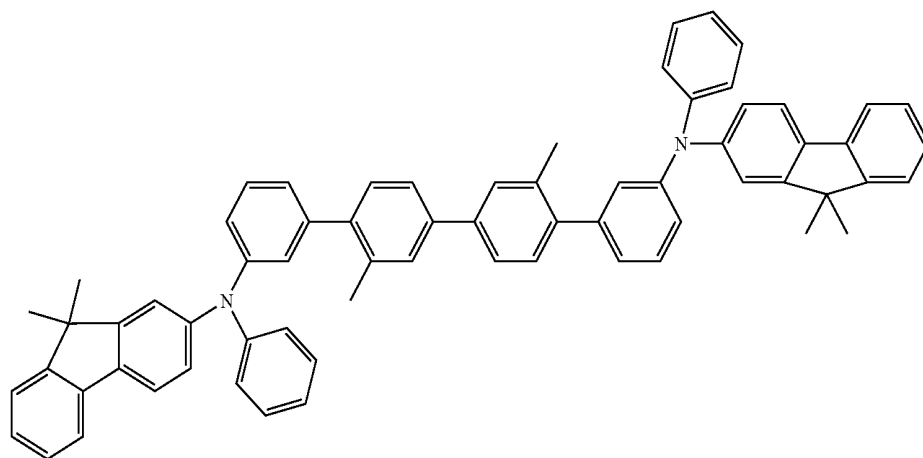

Compound 6

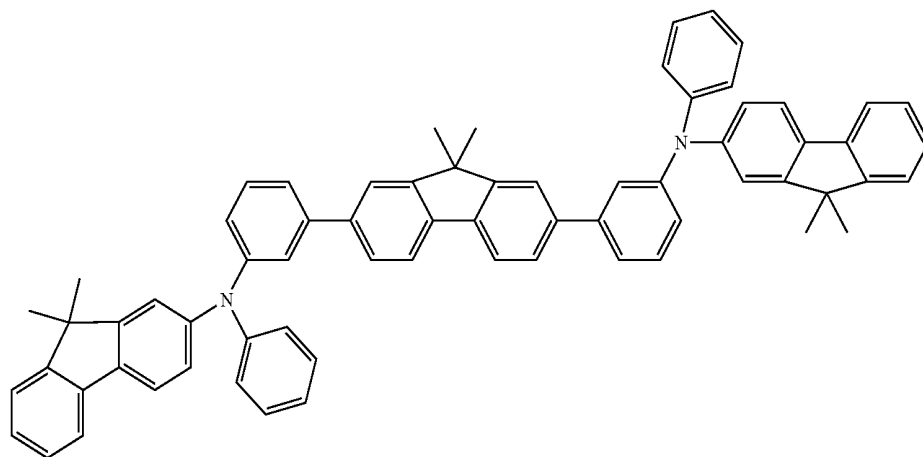

Compound 7

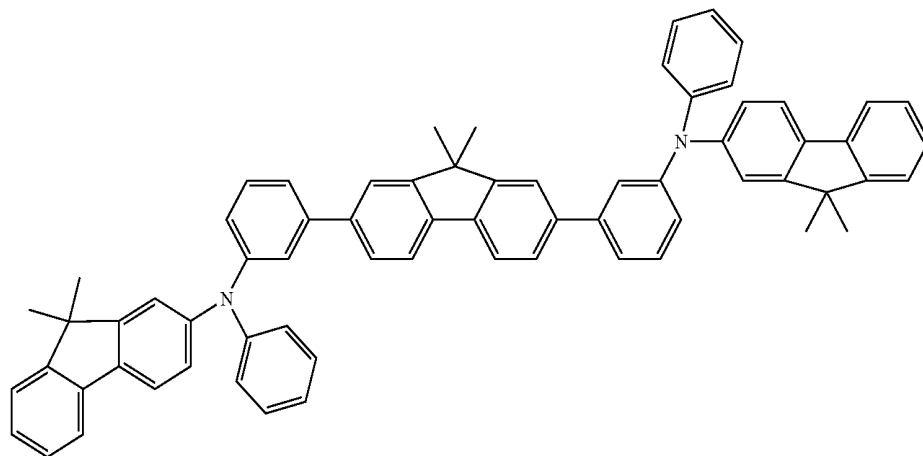

Compound 8

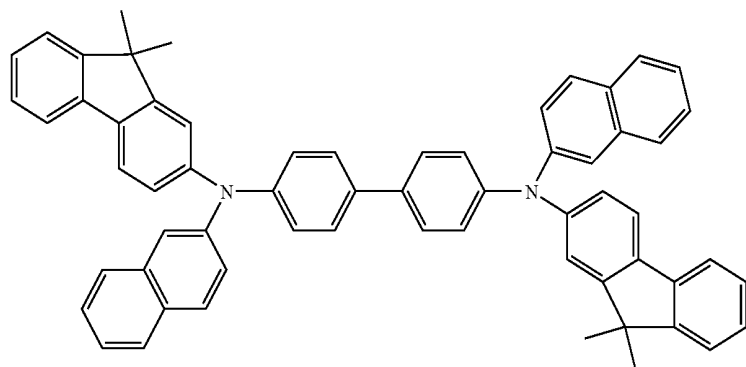

-continued

Compound 9

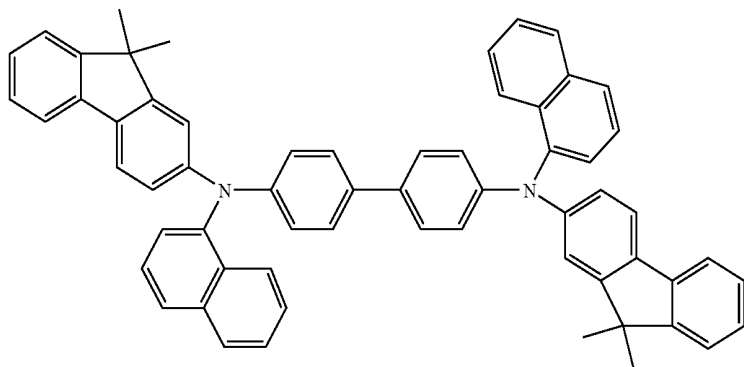

Compound 10

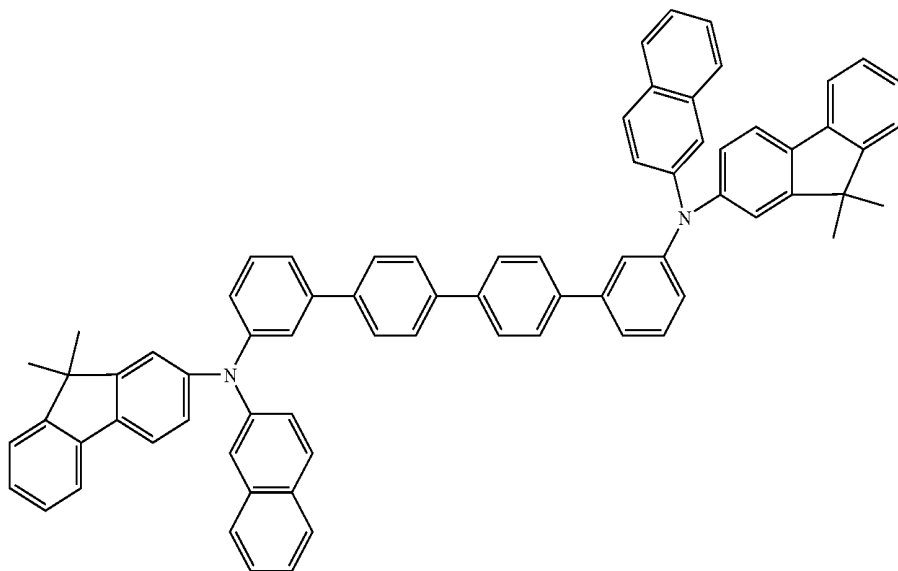

Compound 11

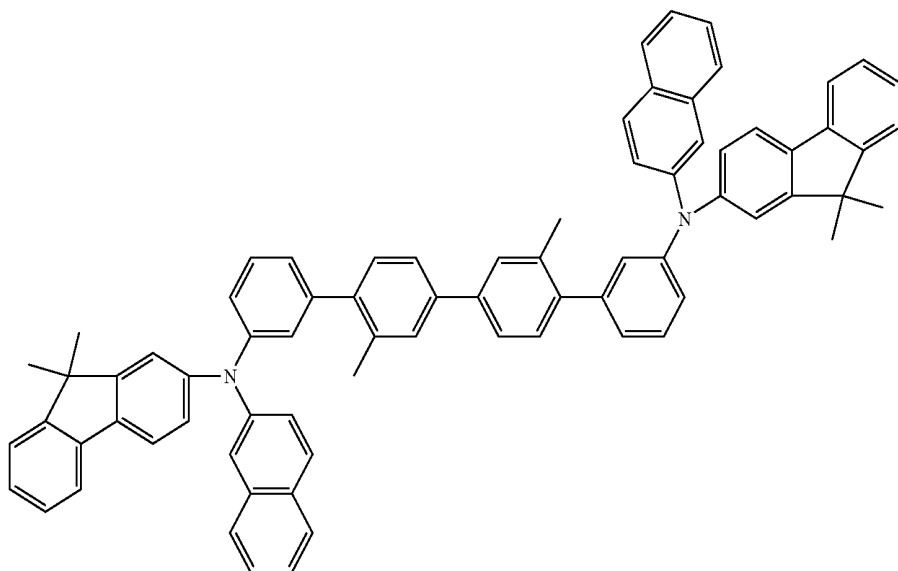

-continued

Compound 12

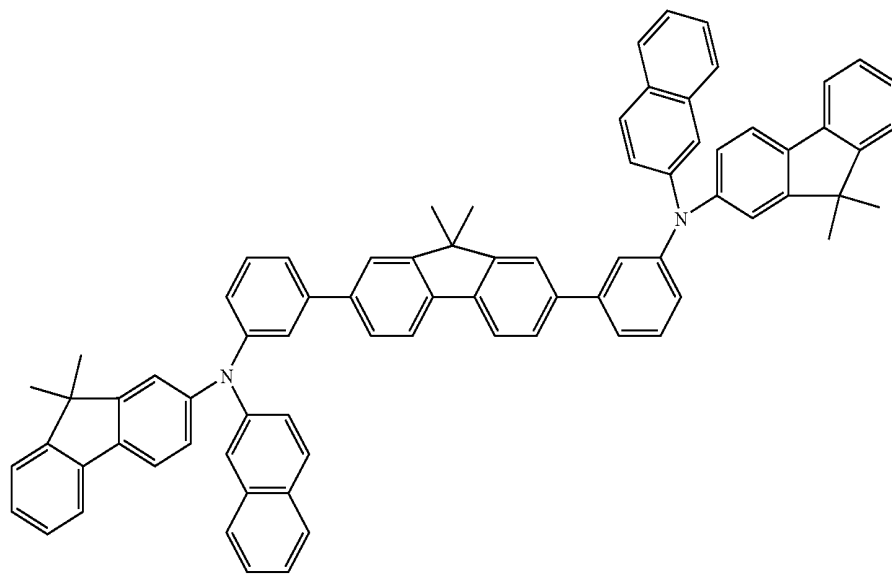

Compound 13

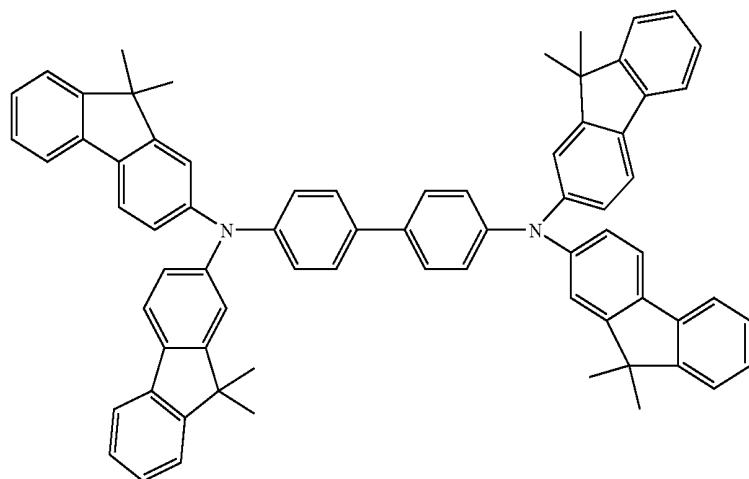

Compound 14

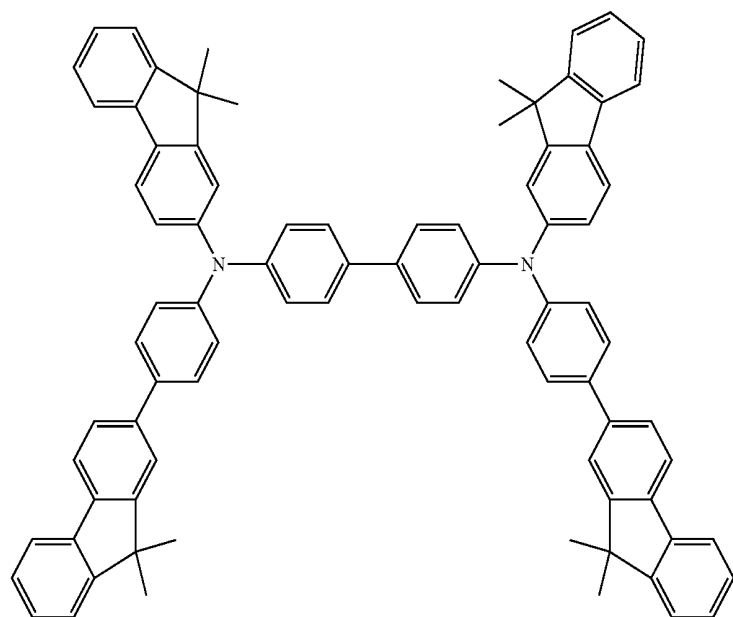

15

16

-continued

Compound 15

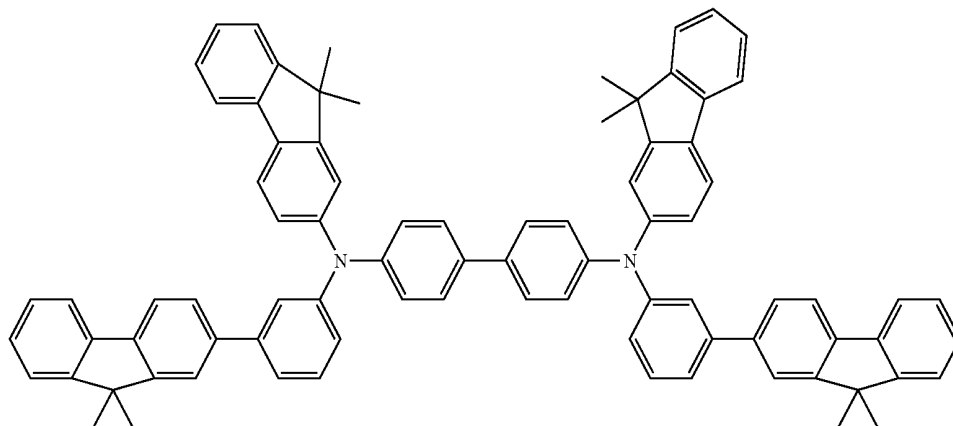

Compound 16

Compound 17

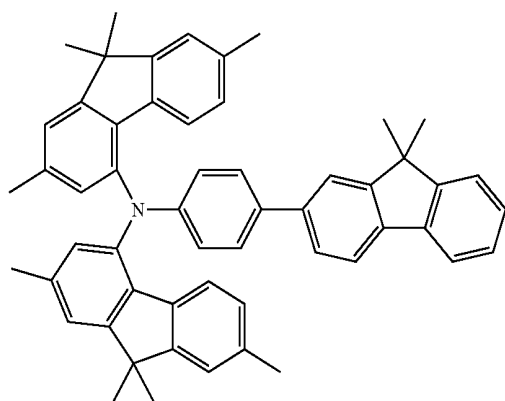

Compound 18

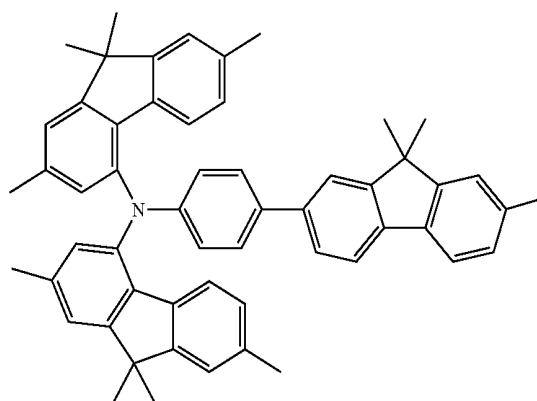

Compound 19

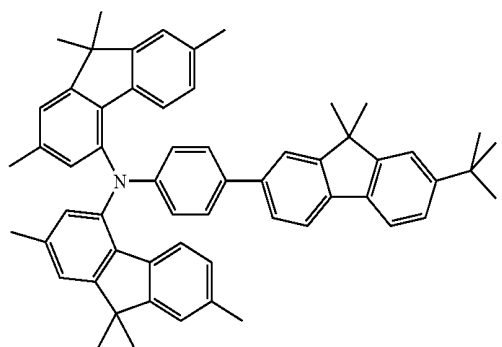

Compound 20

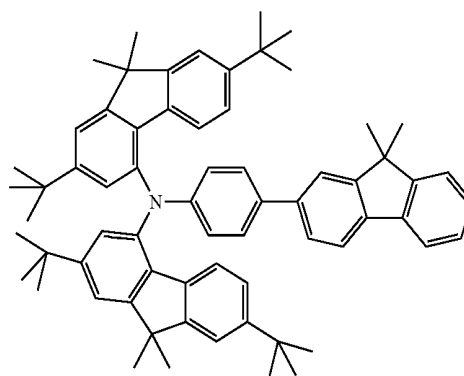

Compound 21

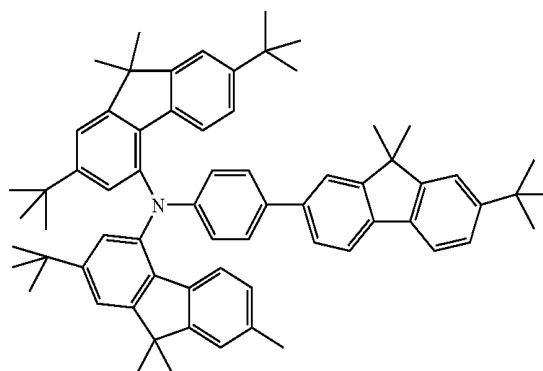
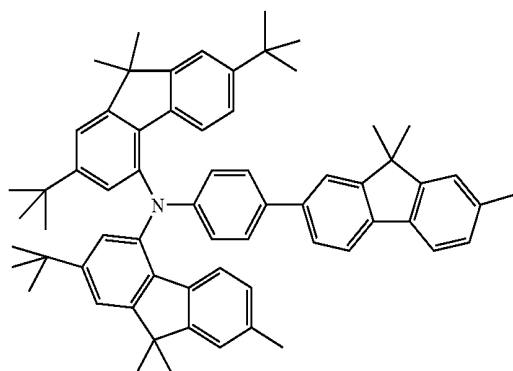

17

18

-continued
Compound 22

Compound 23

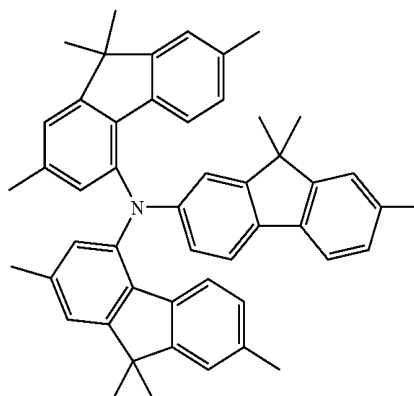
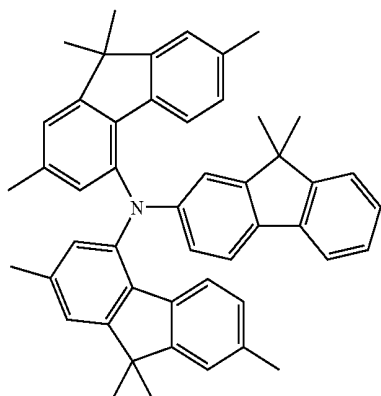

Compound 24

Compound 25

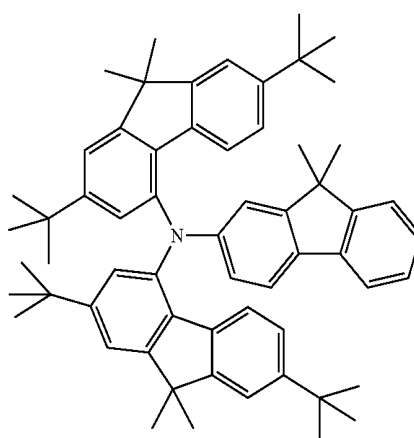
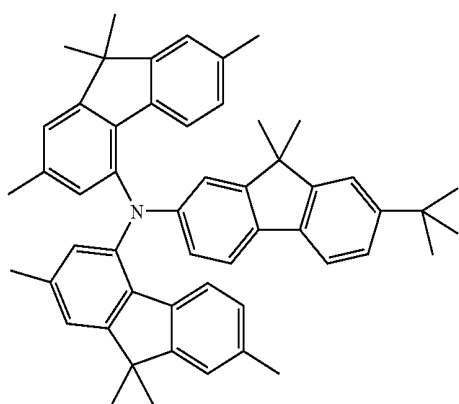

Compound 26

Compound 27

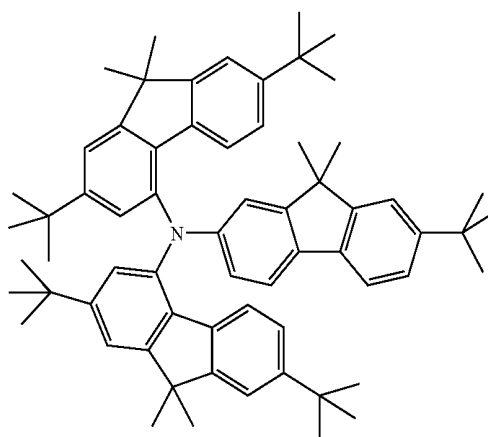
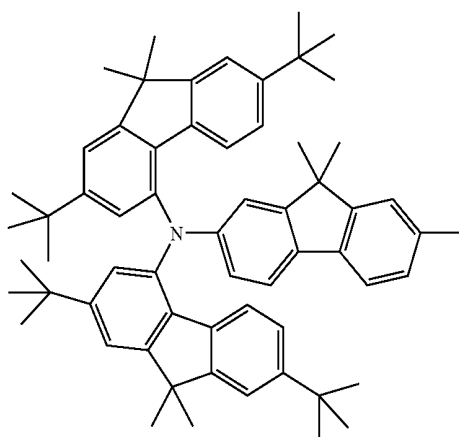

Compound 28

Compound 29

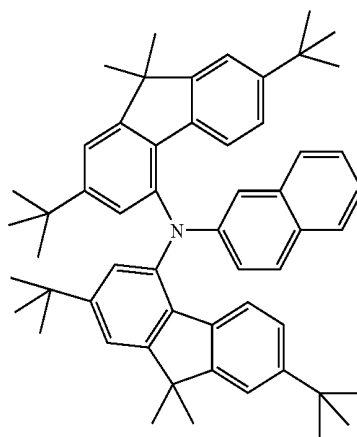
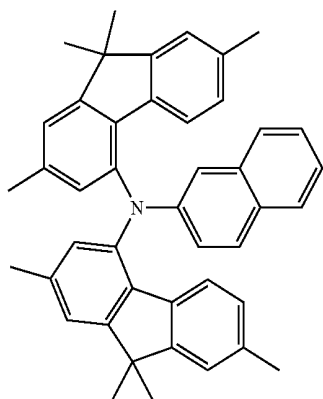

19

20

-continued

Compound 30

Compound 31

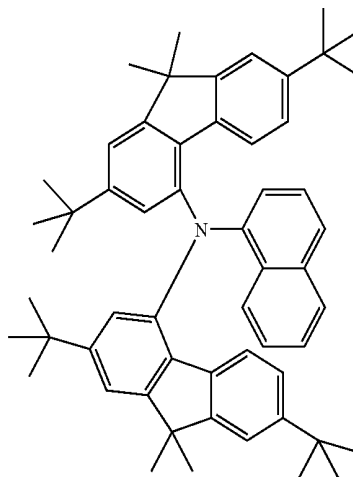
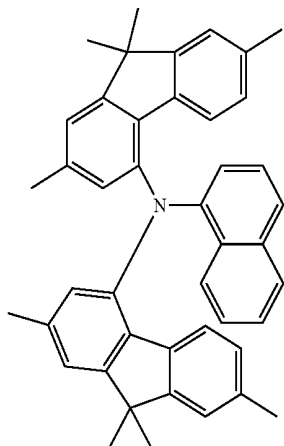

Compound 32

Compound 33

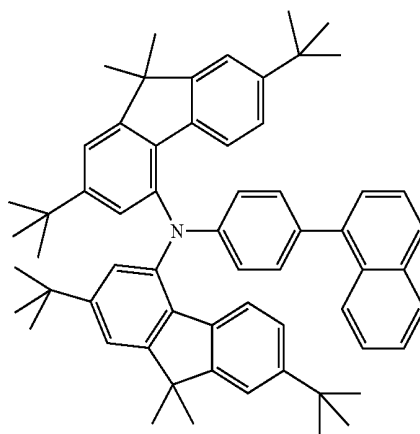
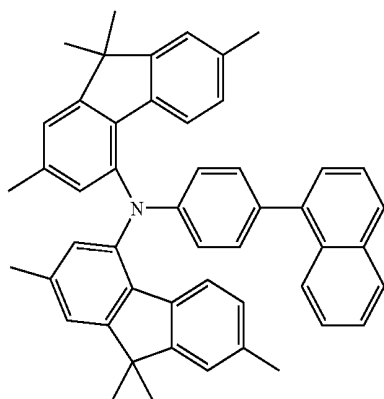

Compound 34

Compound 35

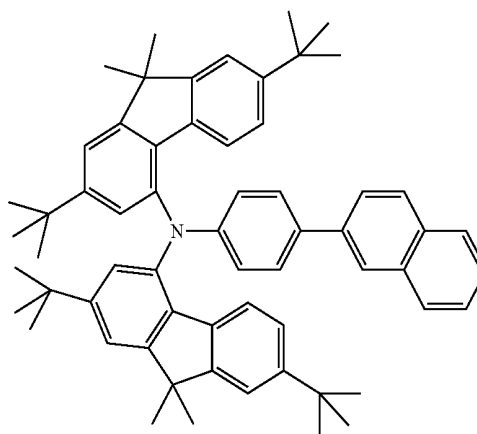
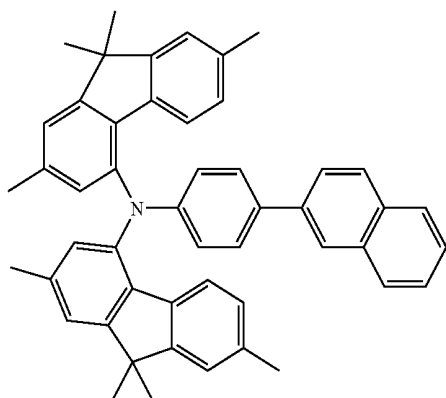

-continued
Compound 36

Compound 37

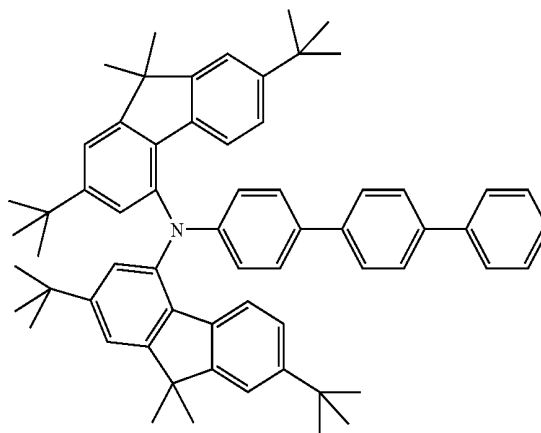
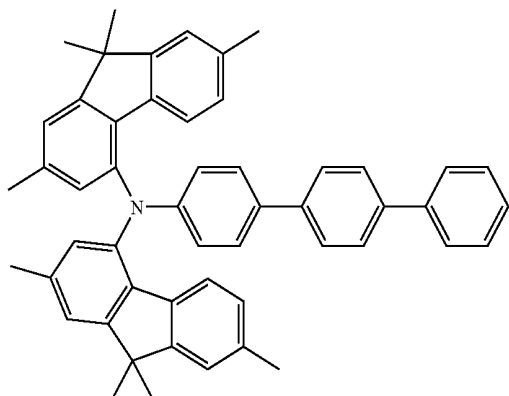

EXAMPLES

The present invention will be specifically described with reference to the examples below, although the present invention is not limited to the examples.

First, common parts of active-matrix displays in the examples of the present invention will be described.

FIG. 6 is a schematic diagram of an example of a TFT matrix organic EL panel according to the present invention. The panel is provided with a drive circuit including a scanning signal driver and a current supply source and a display signal input unit (image information supply unit) including an information signal driver. The scanning signal driver, the current supply source, and the information signal driver are connected to x-direction scanning lines (gate lines), current supply lines, and y-direction lines (information lines), respectively. The information signal driver supplies image signals in synchronization with sequential selection of the gate scanning lines by the scanning signal driver. Display pixels are disposed at the intersections of the gate scanning lines and the information lines.

FIG. 7 is a schematic sectional view of a TFT used in the examples of the present invention. A polysilicon layer is formed on a glass substrate and is doped with appropriate dopants to form a channel region, a drain region, and a source region. A gate insulating film is formed on the polysilicon layer, and a gate electrode is formed on the gate insulating film. A drain electrode and a source electrode are formed so that they are connected to the drain region and the source region, respectively. The drain electrode is also connected to a pixel electrode via a contact hole of an interlayer insulating film.

An organic light-emitting layer is formed on the pixel electrode, and a cathode is formed on the light-emitting layer, so that an active-matrix organic EL device is provided. In the examples of the present invention, the pixel electrode is formed as an anode by depositing and patterning a chromium layer and a transparent IZO electrode layer with a thickness of 60 nm so as to define a display including 100 by 100 pixels having a pixel size of 60 μm by 90 μm and arranged at intervals of 40 μm .

Example 1

Formation of Common Hole-Injecting Layer

A TFT substrate having the anode described above was prepared. A common hole-injecting layer was formed on the anode by vacuum deposition using Compound 1 in a vacuum of 5.0×10^{-5} Pa at a deposition rate of 0.1 to 0.2 nm/sec. The common hole-injecting layer thus formed had a thickness of 20 nm.

Formation of Red Light-Emitting Layer

A deposition mask having openings corresponding to red pixels was placed over a large number of pixels arranged in two dimensions.

A hole-transporting layer for the red pixels having a thickness of 60 nm was formed using Compound 1. A light-emitting layer having a thickness of 25 nm was then formed by codeposition of Compound 38, as a host, and Compound 39, as a luminescent material, in a weight ratio of 87:13. Compounds 38 and 39 have the following structures:

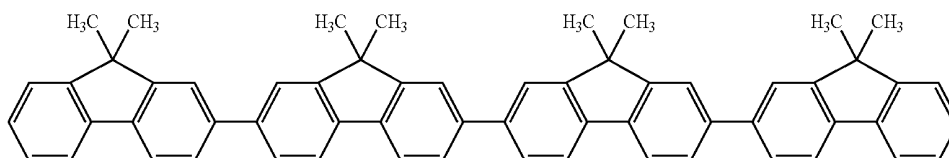

Compound 38

-continued

Compound 39

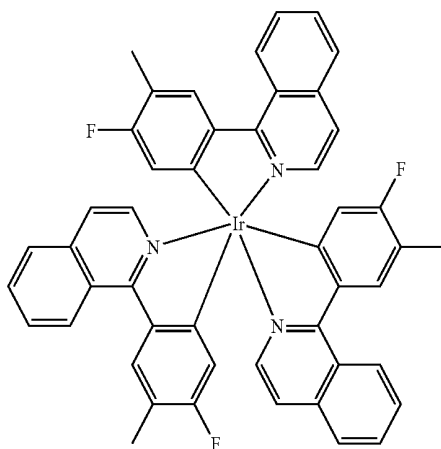

Formation of Green Light-Emitting Layer

A deposition mask having openings corresponding to green pixels was placed over the pixels.

A hole-transporting layer for the green pixels having a thickness of 20 nm was formed using Compound 1. A light-emitting layer having a thickness of 25 nm was then formed by codeposition of Compound 40, as a host, and Compound 41, as a luminescent material, in a weight ratio of 90:10. Compounds 40 and 41 have the following structures:

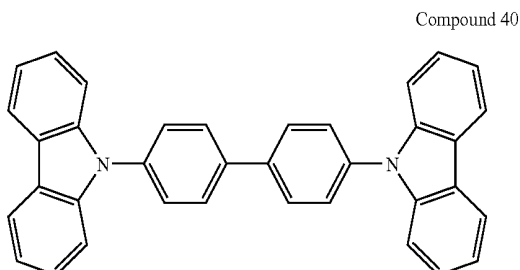

Compound 40

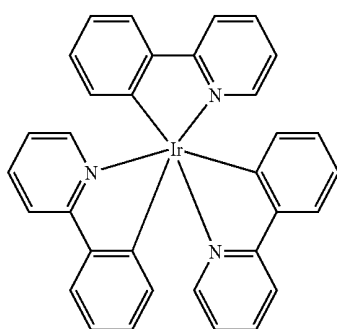

Compound 41

Formation of Blue Light-Emitting Layer

A deposition mask having openings corresponding to blue pixels was placed over the pixels.

A hole-transporting layer for the blue pixels having a thickness of 20 nm was formed using Compound 6. A light-emitting layer having a thickness of 20 nm was then formed by

codeposition of Compound 42, as a host, and Compound 43, as a luminescent material, in a weight ratio of 90:10. Compounds 42 and 43 have the following structures:

Compound 42

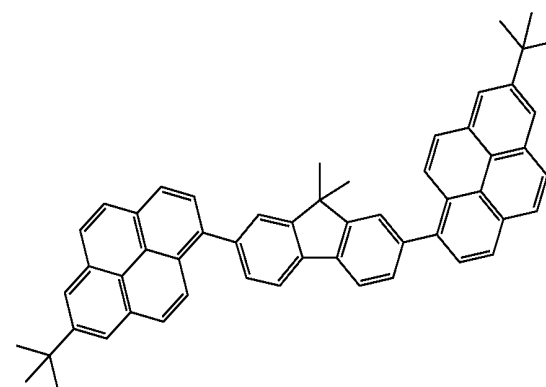

25

30

35

40

45

50

55

60

Compound 43

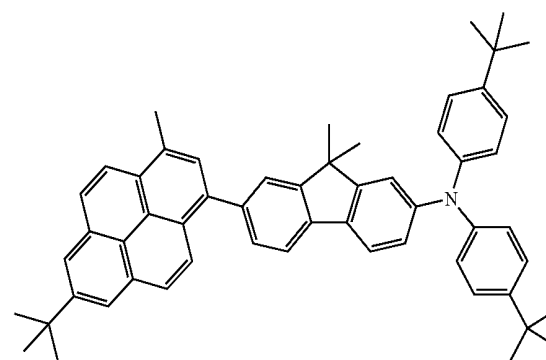

Formation of Electron-Transporting Layer and Electron-Injecting Layer

The deposition mask was removed for deposition over the entire pixel region. An electron-transporting layer having a thickness of 10 nm was deposited using Compound 44, which has the following structure:

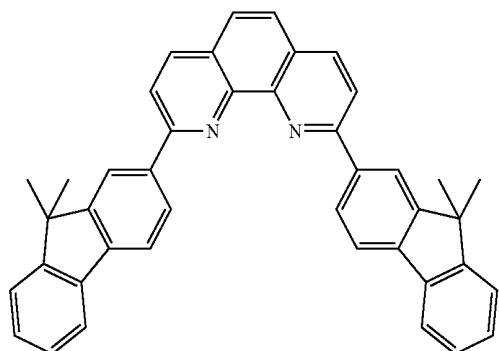

An electron-injecting layer having a thickness of 40 nm was then formed by codeposition of metallic cesium discharged from an alkali dispenser and Compound 44 in a weight ratio of 90:10.

Formation of Cathode

The substrate having the above organic layers was introduced into a DC sputtering apparatus (manufactured by Osaka Vacuum Ltd.). An ITO film having a thickness of 2,000 Å was deposited on the organic layers by sputtering using a mixture gas of argon and oxygen (in a volume ratio of 200:1) as a sputtering gas at a pressure of 0.3 Pa and a DC output of 40 W to form a transparent cathode capable of outputting light. Thus, red, green, and blue organic EL devices having TFTs were prepared.

The devices thus prepared were sealed by stacking a glass substrate with a UV-curable resin in a glove box with a dew point of not more than -90°C .

Thus, a top-emission RGB full-color organic EL panel was produced which had the hole-injecting layer, the hole-transporting layers, the light-emitting layers, the electron-transporting layer, the electron-injecting layer, and the transparent cathode on the TFT substrate.

The red, green, and blue pixels of the full-color display were driven to emit white light.

The white light was obtained when the luminance ratio between red light, green light, and blue light was 3:6:1. The CIE chromaticity coordinates of the white light, (x, y), were (0.30, 0.32).

Emission of red light was observed with a maximum light emission wavelength of 620 nm and a luminance of 1,500 cd/m^2 at an applied voltage of 4.3 V.

Emission of green light was observed with a maximum light emission wavelength of 520 nm and a luminance of 3,000 cd/m^2 at an applied voltage of 3.8 V.

Emission of blue light was observed with a maximum light emission wavelength of 460 nm and a luminance of 500 cd/m^2 at an applied voltage of 3.1 V.

The red, green, and blue pixels were driven with constant current at the above initial luminances. The time that elapsed before the pixels lost half their initial luminances was measured to be not less than 10,000 hours for every color.

A full-color organic EL panel was produced by the same method as in Example 1 except that the hole-transporting layers for the red pixels and the green pixels were formed of Compounds 4 and 3, respectively.

The red, green, and blue pixels of the full-color display were driven to emit white light.

The white light was obtained when the luminance ratio between red light, green light, and blue light was 3:6:1. The CIE chromaticity coordinates of the white light, (x, y), were (0.30, 0.32).

Emission of red light was observed with a maximum light emission wavelength of 620 nm and a luminance of 1,500 cd/m^2 at an applied voltage of 4.3 V.

Emission of green light was observed with a maximum light emission wavelength of 520 nm and a luminance of 3,000 cd/m^2 at an applied voltage of 3.8 V.

Emission of blue light was observed with a maximum light emission wavelength of 460 nm and a luminance of 500 cd/m^2 at an applied voltage of 3.1 V.

The red, green, and blue pixels were driven with constant current at the above initial luminances. The time that elapsed before the pixels lost half their initial luminances was measured to be not less than 10,000 hours for every color.

Comparative Example 1

A full-color organic EL panel was produced by the same method as in Example 1 except that the hole-transporting layer for the red pixels was formed of Compound 45, which has the following structure:

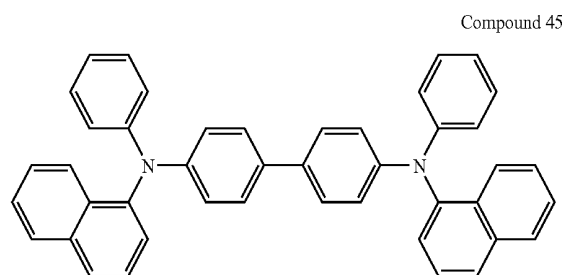

The red, green, and blue pixels of the full-color display were driven to emit white light.

The white light was obtained when the luminance ratio between red light, green light, and blue light was 3:6:1. The CIE chromaticity coordinates of the white light, (x, y), were (0.30, 0.32).

With the initial characteristics of the full-color organic EL panel, emission of red light was observed with a luminance of 1,500 cd/m^2 at an applied voltage of 4.6 V. When the entire panel was caused to illuminate in red, dead pixels and fogging due to crystallization were observed.

27

The red, green, and blue pixels were driven with constant current at the same initial luminances as in Examples 1 and 2. The time that elapsed before the red pixels lost half their initial luminances was measured to be not more than half those measured in Examples 1 and 2.

Comparative Example 2

A full-color organic EL panel was produced by the same method as in Example 2 except that the common hole-injecting layer was formed of Compound 46, which has the following structure:

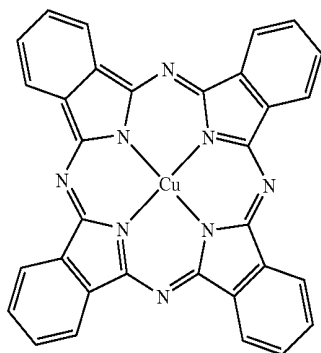

Compound 46

The red, green, and blue pixels of the full-color display were driven to emit white light.

The white light was obtained when the luminance ratio between red light, green light, and blue light was 3:6:1. The CIE chromaticity coordinates of the white light, (x, y), were (0.30, 0.32).

With the initial characteristics of the full-color organic EL panel, emission of red light was observed with a luminance of 1,500 cd/m² at an applied voltage of 5.3 V. Emission of green light was observed with a luminance of 3,000 cd/m² at an applied voltage of 4.8 V. Emission of blue light was observed with a luminance of 500 cd/m² at an applied voltage of 5.2 V. Dead pixels were observed in the entire panel.

The red, green, and blue pixels were driven with constant current at the same initial luminances as in Examples 1 and 2. The time that elapsed before the pixels lost half their initial luminances was measured to be not more than half those measured in Examples 1 and 2 for every color.

While the present invention has been described with reference to exemplary embodiments, it is to be understood that the invention is not limited to the disclosed exemplary

28

embodiments. The scope of the following claims is to be accorded the broadest interpretation so as to encompass all modifications, equivalent structures and functions.

This application claims the benefit of Japanese Application No. 2006-088353 filed Mar. 28, 2006, which is hereby incorporated by reference herein in its entirety.

What is claimed is:

1. A full-color organic electroluminescent panel having red (R), green (G), and blue (B) color pixels that independently emit light, the organic electroluminescent panel comprising:
 - a hole-injecting layer common to the red (R), green (G), and blue (B) color pixels; and
 - a plurality of hole-transporting layers, wherein the hole-transporting layer in at least one of the red (R), green (G), or blue (B) color pixels differs from a corresponding hole-transporting layer in the remaining pixels
 wherein the red (R) color pixel and the green (G) color pixel include phosphorescent materials, and the blue (B) color pixel includes a fluorescent material, and wherein materials of the hole-transporting layer and the hole-injecting layer have a common component represented by the general formula (1):

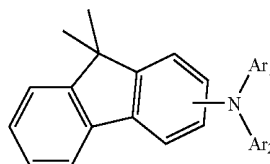

(1)

wherein Ar₁ and Ar₂ are each a substituted or unsubstituted aryl group.

2. The full-color organic electroluminescent panel according to claim 1, further comprising at least one of an electron-transporting layer or an electron-injecting layer common to the red (R), green (G), and blue (B) color pixels.
3. The full-color organic electroluminescent panel according to claim 1, wherein the phosphorescent material comprises an iridium complex.
4. The full-color organic electroluminescent panel according to claim 3, wherein each of the hole-injecting layers of the red (R), green (G), and blue (B) color pixels has compound 1:

29

30

wherein the hole-transporting layer of the green (G) color pixel has the compound 1 and a light-emitting layer of the green (G) color pixel has compound 41:

Compound 1

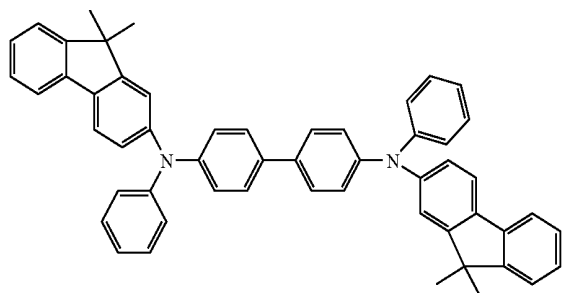

5

10

15

wherein the hole-transporting layer of the red (R) pixel has the compound 1 and a light-emitting layer of the red (R) pixel has compound 39:

Compound 39

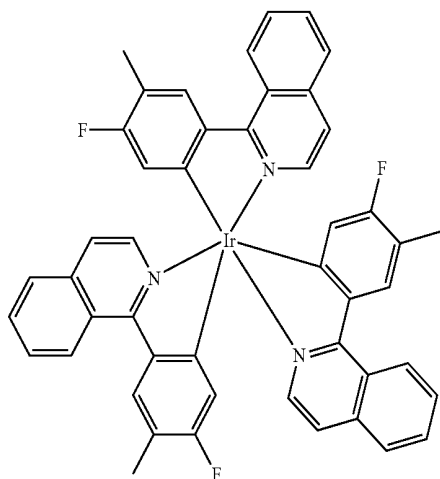

20

25

30

35

40

wherein the hole-transporting layer of the blue (B) color pixel has compound 6 and a light-emitting layer of the blue (B) color pixel has compound 43:

Compound 41

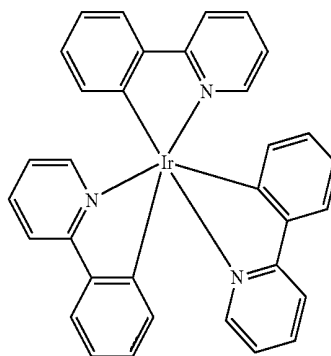

Compound 6

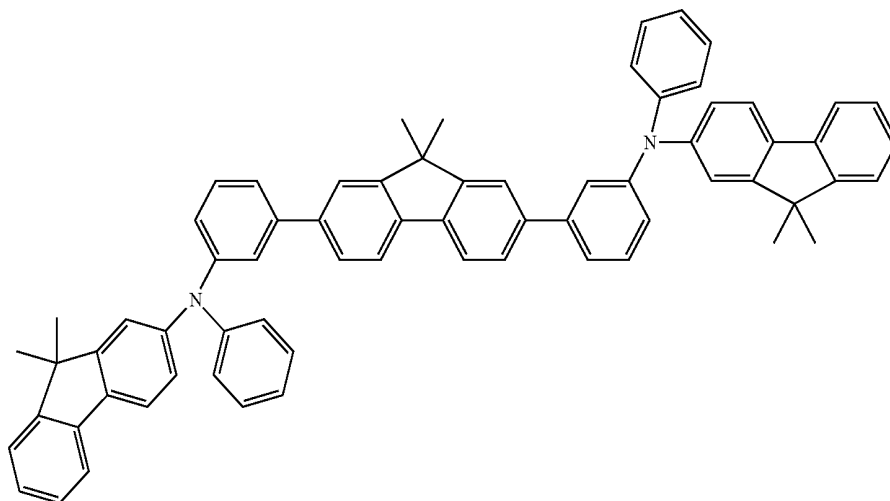

31

32

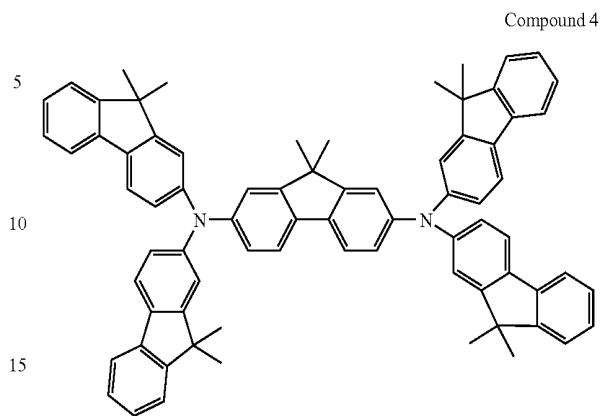
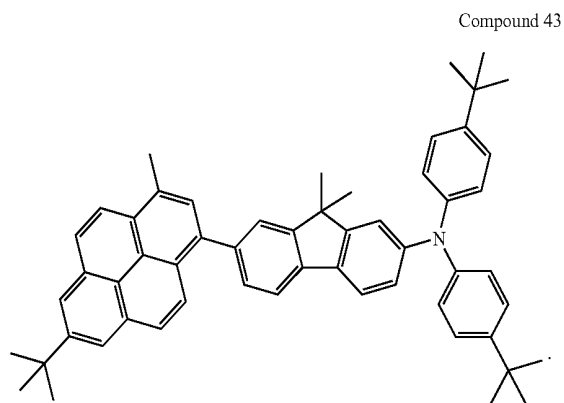

5. The full-color organic electroluminescent panel according to claim 3, wherein each of the hole-injecting layers of the red (R), green (G), and blue (B) color pixels has compound 1:

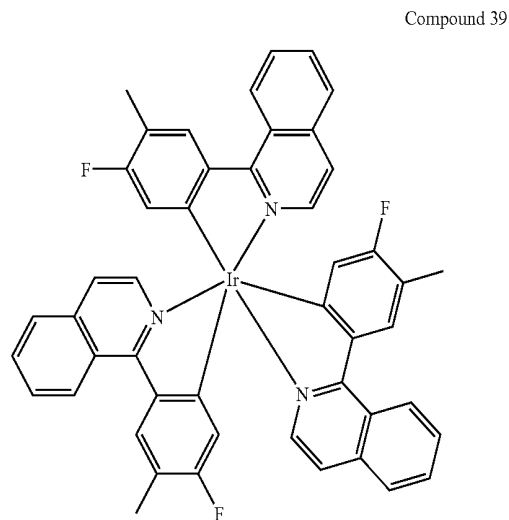
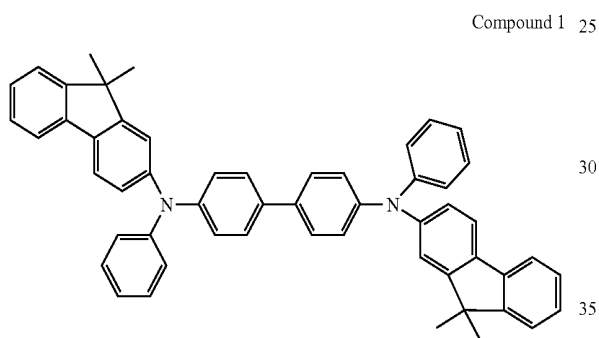

wherein the hole-transporting layer of the red (R) pixel has the compound 4 and a light-emitting layer of the red (R) pixel has compound 39:

wherein the hole-transporting layer of the green (G) color pixel has the compound 3 and a light-emitting layer of the green (G) color pixel has compound 41:

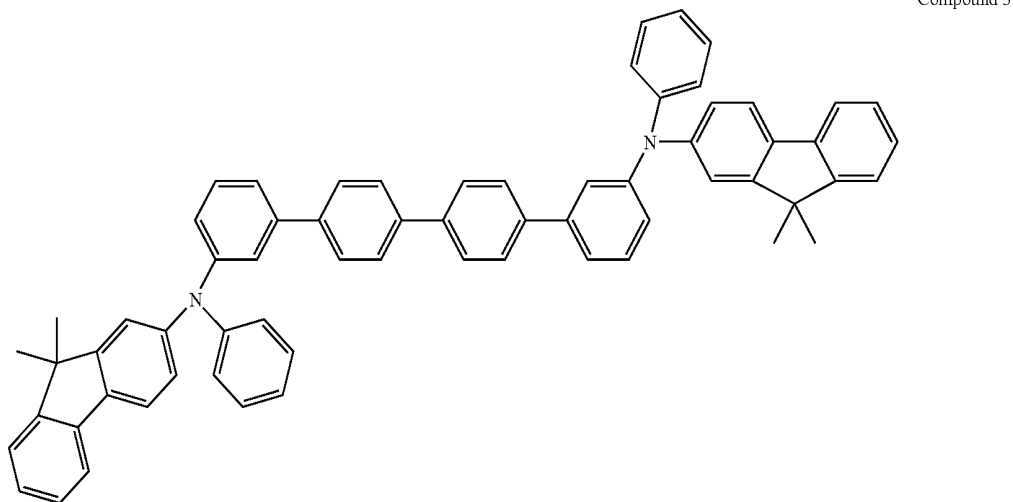

33

34

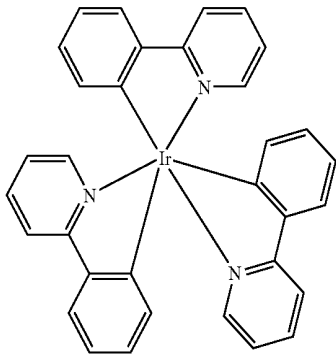

Compound 41

5

10

15

20

wherein the hole-transporting layer of the blue (B) color pixel has compound 6 and a light-emitting layer of the blue (B) color pixel has compound 43:

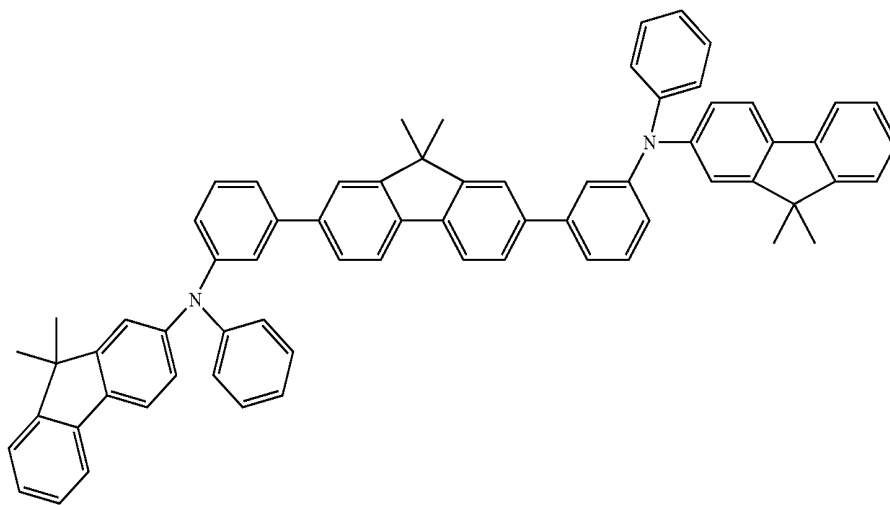

Compound 6

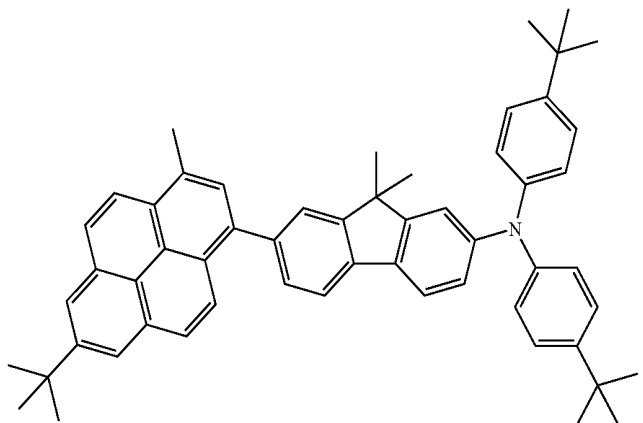

Compound 43

* * * * *

专利名称(译)	全彩有机el面板		
公开(公告)号	US7799442	公开(公告)日	2010-09-21
申请号	US11/689612	申请日	2007-03-22
[标]申请(专利权)人(译)	佳能株式会社		
申请(专利权)人(译)	佳能株式会社		
当前申请(专利权)人(译)	佳能株式会社		
[标]发明人	IWAWAKI HIRONOBU OKADA SHINJIRO TAKIGUCHI TAKAO IGAWA SATOSHI		
发明人	IWAWAKI, HIRONOBU OKADA, SHINJIRO TAKIGUCHI, TAKAO IGAWA, SATOSHI		
IPC分类号	H01L51/54		
CPC分类号	H01L51/006 H01L51/5048 H01L27/3211 H01L27/3244 Y10S428/917 H01L51/5016 Y10T428/2495 H01L51/0085		
优先权	2006088353 2006-03-28 JP		
其他公开文献	US20070228399A1		
外部链接	Espacenet USPTO		

摘要(译)

全色有机电致发光面板具有独立发光的红色 (R) , 绿色 (G) 和蓝色 (B) 彩色像素。有机电致发光面板包括红色 (R) , 绿色 (G) 和蓝色 (B) 彩色像素共用的空穴注入层和多个空穴传输层。红色 (R) , 绿色 (G) 或蓝色 (B) 颜色像素中的至少一个中的空穴传输层与其余像素中的相应空穴传输层不同。

PANEL

